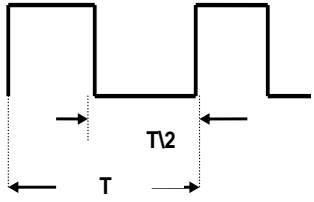

Sayıcılarda Özel Kontaktörlerle Uygulamalar

Kontaktör Numarası		Açıklama
F090	20 msan	
F091	100 msan	
F092	200 msan	
F093	1 san	
F094	2 san	
F095	10 san	
F096	20 san	
F097	1 dak	

1 K10S1 tipi PLC içerisindeki sürekli darbeler üreten özel kontaktörler

Örnek 4.5

PLC denetimli yapıda “Başla” anahtarı kapalı olduğu zaman PLC çıkışına bağlanan motor

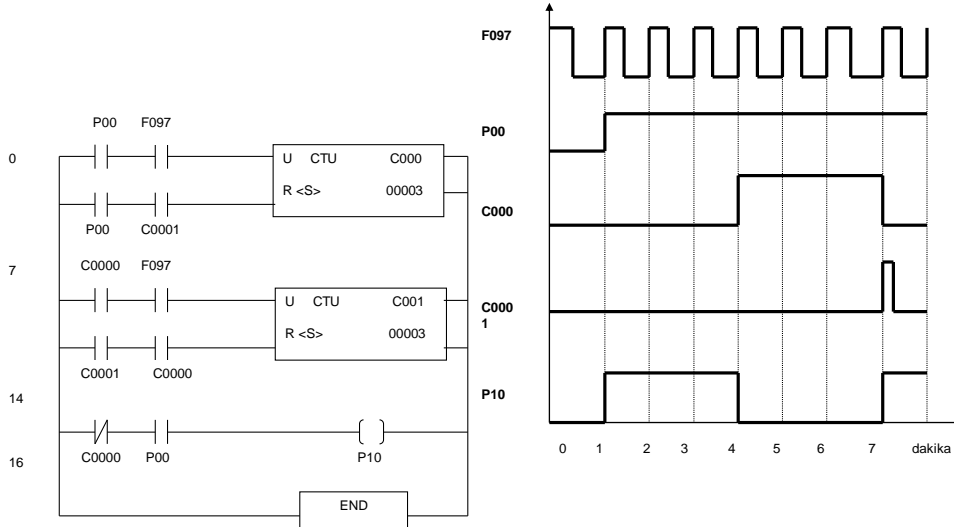
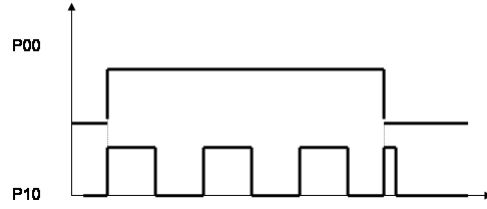
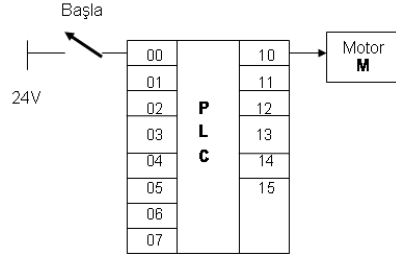

Sayıcılarla Zamanlayıcıların Birlikte Kullanımları

Örnek 4.6

Sistemin denetimi aşağıda açıklanan kıstasları kapsayacaktır;

.....
.....
.....
.....
.....
.....
.....
.....
.....
.....
.....
.....
.....
.....
.....
.....

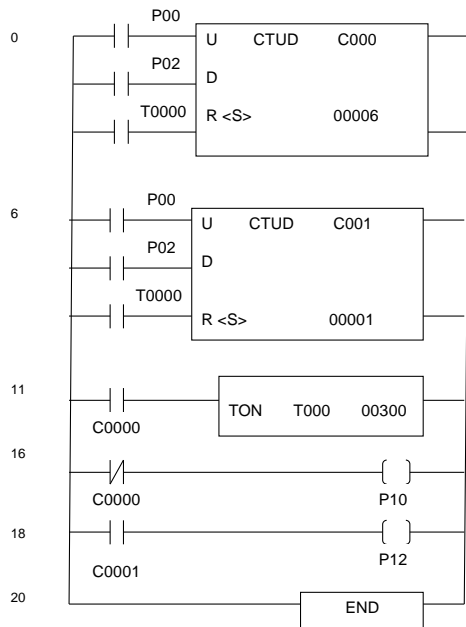
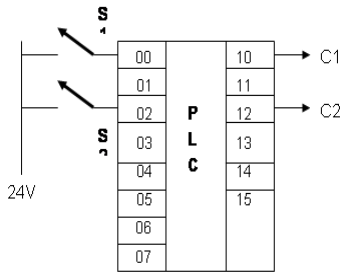
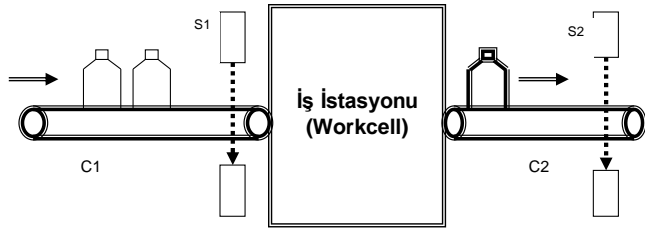

Örnek 4.7

PLC ile motor kontrol devresinde aşağıdaki kriterleri karşılayacak şekilde bir PLC denetim

.....

.....

.....

.....

.....

.....

.....

